

Sys-
tem
Cata-
logue

air-lux SW 75 sliding window



air-lux SW 75 system

100% impermeable, excellent running characteristics

that could previously only be achieved with side-hung windows. When the gasket is open (gasket is deflated), the gasket is rolled up and the sliding window can be moved with minimum effort. Unlike in systems with brush or slide gasket, no trade-offs need to be made between tightness and running characteristics.

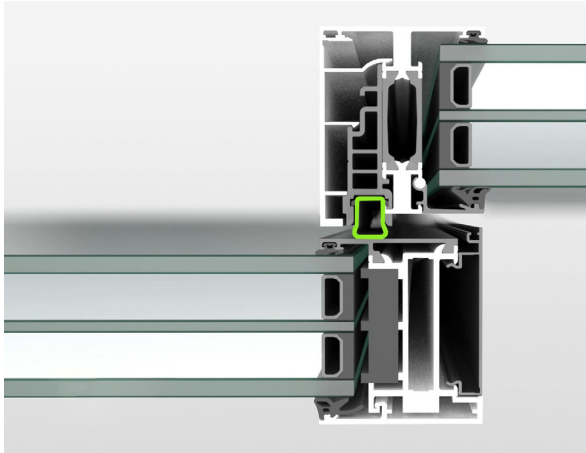

Inflated gasket

When the button is pressed, air is pumped into the gasket. The gasket presses against the sliding sash and tightly seals the gap between the sliding sash and the frame.

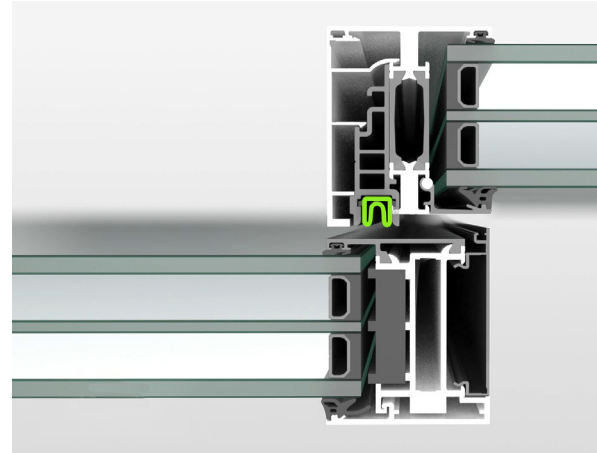

Deflated gasket

To open the window, press the button. This deflates the gasket, which causes it to detach from the sliding sash. The sliding window can now be opened.



air-lux.com/en



air-lux.com/sliding-window

air-lux SW 75 system



Button

The button is the central control and display element and is used for unlocking, locking and status display in addition to fault and error display.



Motherboard

The motherboard is an electronic component used in every window to process electrical signals, trigger actions and control the window's functions. It contains circuits, microcontrollers and interfaces to connect sensors, process data and send control commands to other parts of the window.



Locking bolt

The sliding window features a locking system with an electrically controlled locking bolt. In the event of a power failure an open window, whether manual or motorized, can be manually pushed into the closed position. Once in the closed position, the locking bolt will automatically lock. The locking bolt is also available with VdS class C certification.

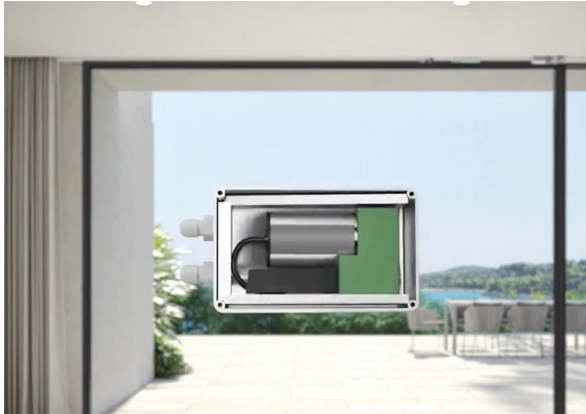
air-lux SW 75 system**Compressor**

The virtually silent, built-in compressor is at the heart of the patented sealing system. It maintains a constant pressure of less than 1 bar through continuous monitoring, ensuring 100% air and water tightness at all times.

**Roller**

The roller and stainless-steel track guarantee optimal running properties of the sliding window. The integrated roller can transfer loads of up to 1,800 kg per sash to the track.

System

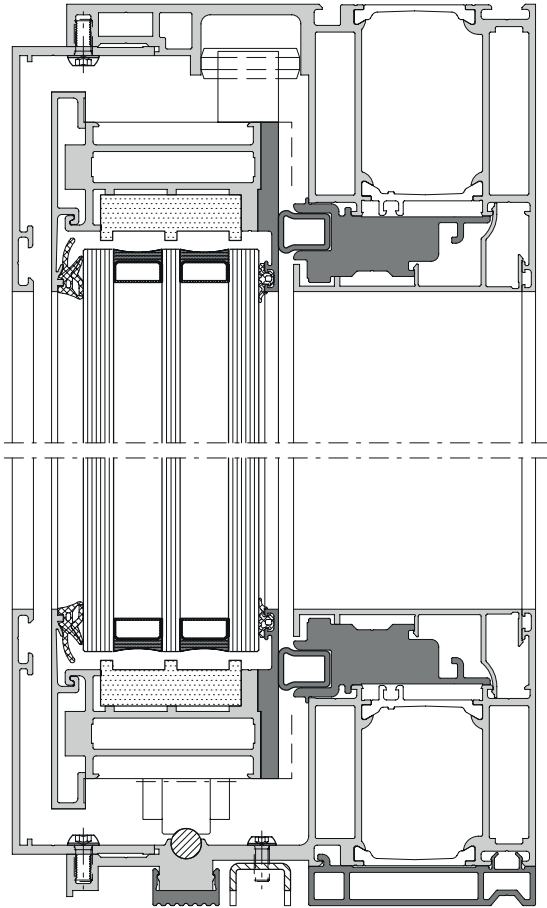

Characteristics and benefits

- Sliding window system with thermally insulated profiles for maximum transparency and natural light transmission
- Inflatable gasket eliminates friction when opening and closing
- Floor-to-ceiling installation
- Exterior sliding sash design ensures clean interior lines
- Compatible with Schüco AWS 75.SI+ and AD-UP 75
- Manual or motorized options available
- All components concealed in the frame
- Zero threshold

Tests and standards*

Wind load resistance in accordance with
DIN EN 12210 up to class C4/B4

Air permeability in accordance with
DIN EN 12207 up to class 4

Water tightness against driving rain in accordance
with DIN EN 12208 up to class EI 1500

Burglar resistance in accordance with
DIN EN 1627* up to class RC3

Thermal insulation in accordance with
DIN EN ISO 10077-2** from 0.8 W/(m²K)

Sound insulation in accordance with
EN ISO 10140 up to 43 dB

Operating forces in accordance with
DIN EN 13115 up to class 2

* Depending on the design (see test certificate)

** Calculation basis: schema A

Element dimensions:

W × H 6,000 mm × 2,500 mm /

Glass: 0.5 W/(m²K), 0.034 psi

**The air-lux SW 75 system may only be installed
by certified or trained metalwork partners**

Sliding window opening types

The air-lux sliding window is a single-track system in which the sliding sash moves on the exterior in front of the fixed glazing. All schema are drawn from the exterior point of view.

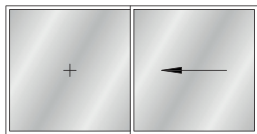

Schema A

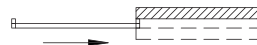
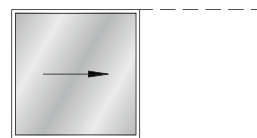

Schema A pocket

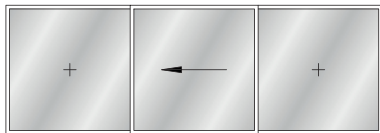

Schema G

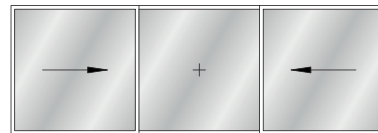

Schema K

air-lux can be used to combine window and door elements.

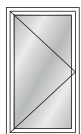

Doors

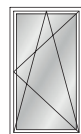

Tilt-and-turn windows



Ventilation sashes

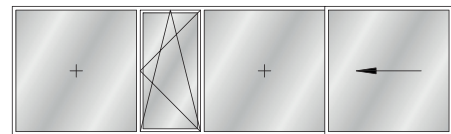

Sliding window schema A and tilt-and-turn window

Sliding window opening types

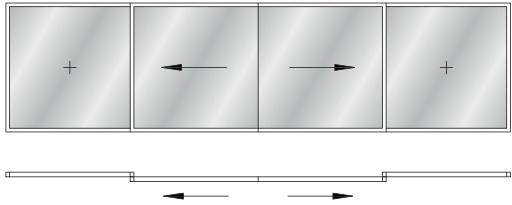

Schema C

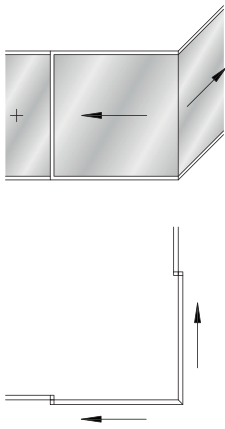

Schema C 1.1

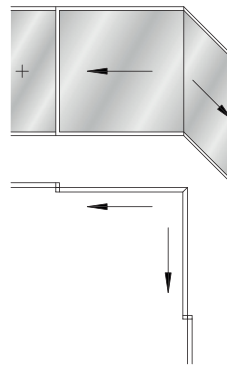

Schema C 1.2

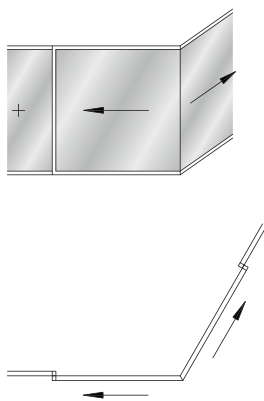

Schema C 1.3

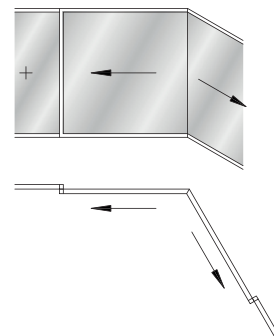

Schema C 1.4

Special solutions

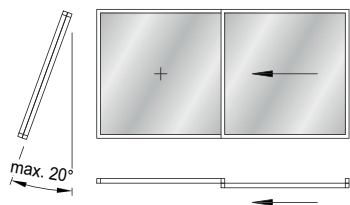

Schema A 2.1

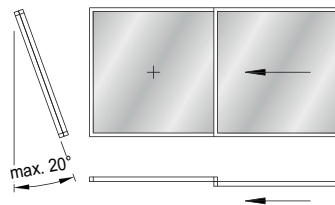

Schema A 2.2

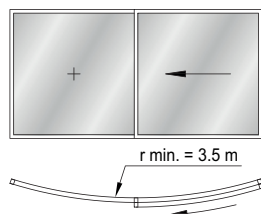

Schema A 3.1

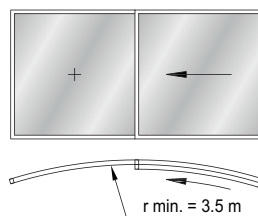

Schema A 3.2

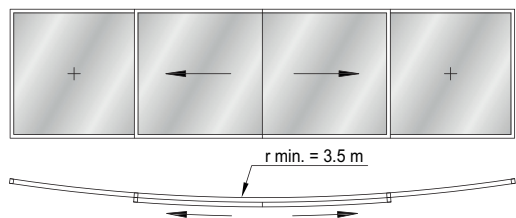

Schema C 3.1

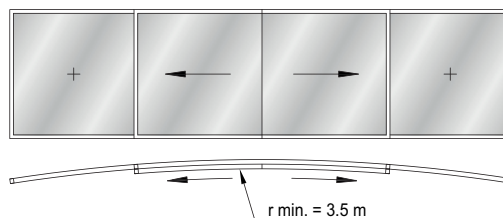

Schema C 3.2

Special applications

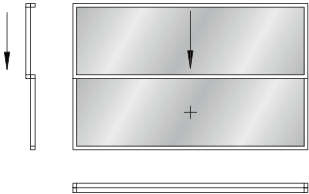

Schema A 5.1

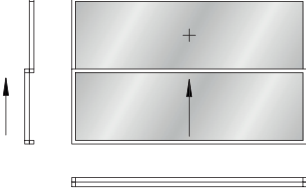

Schema A 5.2

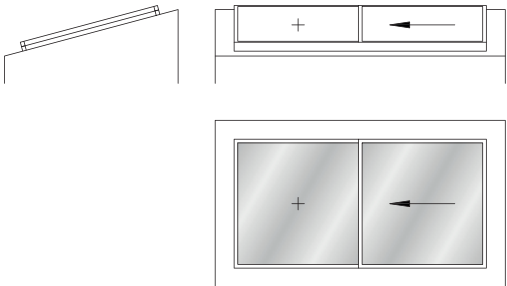

Schema A 6.1

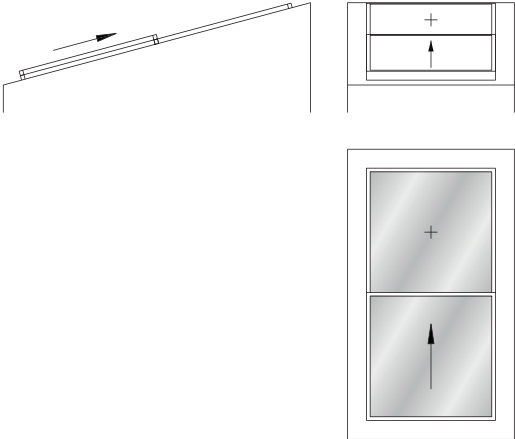

Schema A 6.2

Dimensions available on request.

Dimensions

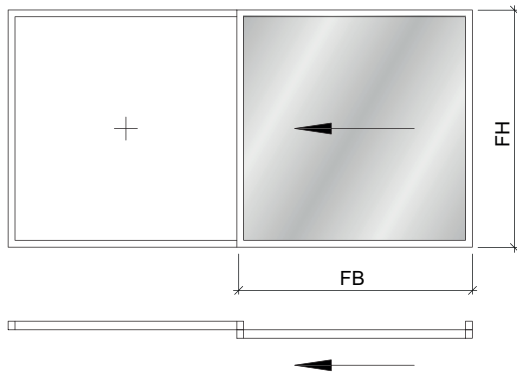

Dimensions – Schema A, G and K

Width: min. SW 1,400 mm
max. SW 6,000 mm

Height: min. SH 700 mm
max. SH 6,000 mm

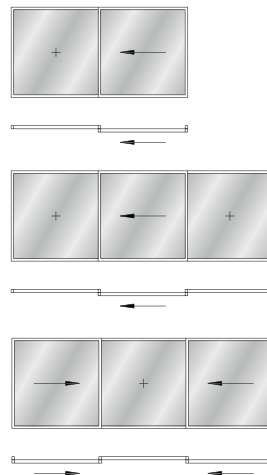

Dimensions – Schema C

Width: min. SW 1,200 mm
max. SW 6,000 mm

Height: min. SH 1,100 mm
max. SH 6,000 mm

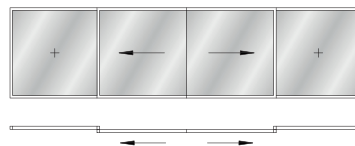

Versions

Motorized Width: min. SW 1,700 mm
RC Width: min. SW 1,800 mm
Motorized threshold Width: min. 700 mm

Area: max. 18 m²
Weight: max. 1,800 kg













Fixed glazing: up to maximum glass sizes

Other dimensions available on request.

SW = sash width
SH = sash height

CE datasheet

Test results for product standard EN 14351-1

	<p>Air permeability Classification to standard EN 12207: 2016-12</p>	up to class 4
	<p>Driving rain impermeability Classification to standard EN 12208:1999-11</p>	up to class E1500
	<p>Noise insulation Dimensions in accordance with DIN EN ISO 10 140-2</p>	up to 43 dB
	<p>Wind load Classification to standard EN 12210: 2016-03</p>	up to class C4/B4
	<p>Thermal insulation Classification to standard EN 10077-1</p>	<p>U_w value/property-specific 0.83 W/m²K, U_g 0.5 W/m²K 0.92 W/m²K, U_g 0.6 W/m²K</p>
	<p>Burglar resistance in accordance with EN 1627-1630</p>	up to RC 3
	<p>Bullet-resistant Special designs up to resistance class BR4-NS</p>	
	<p>Operating forces Classification to standard EN 13115:2020-11</p>	up to class 2
	<p>Fall protection in accordance with DIN 18008-4</p>	Category A
	<p>Roll-over capacity in accordance with ift guideline BA-01/1</p>	up to class 6
	<p>Mechanical durability Classification to standard EN 12400:2002-10</p>	up to class 4
	<p>Safety in use Classification to standard EN 16005:2023+A1</p>	satisfied

US datasheet

AAMA/WDMA/CSA 101/I.S.2/A440-11

Class CW-PG50

Tested dimensions: 10,973 mm/width × 3,962 mm/height (432 in × 156 in)

	<p>Air permeability Classification in accordance with standard ASTM E283-04</p>	<p>0.00 cfm/ft² @ 300 Pa (6.24 psf)</p>
	<p>Driving rain impermeability Classification to standard ASTM E331-09 Uniform pressure ASTM E547-09 Cyclic pressure</p>	<p>No entry @ 958 Pa (20psf) No entry @ 958 Pa (20psf)</p>
	<p>Wind load Classification to standard Uniform structural load Design pressure ASTM E330-02 (10) ASTM E330-02 (10) Deglazing ASTM E987-88 (09)</p>	<p>+/- 2394 Pa (+/- 50 psf) +/- 3591 Pa (+/- 75 psf) No damage</p>
	<p>Hurricanes Classification to standard TAS 201/2002/203</p>	<p>HVHZ, wind zone 4, large and small missile impact</p>
	<p>Burglar resistance Classification to standard ASTM F842-04 Forced Entry</p>	<p>Burglar resistance Classification in accordance with standard ASTM F842-04 Forced Entry</p>
	<p>Bullet-resistant Special designs up to resistance class BR4-NS</p>	<p>Window height up to 3 m</p>
	<p>Operating capacity Classification to standard ASTM E2068</p>	<p>12.4 lbf initial/13.8 lbf</p>
	<p>Thermal insulation Classification to standard NFRC glazed wall system NFRC sliding door</p>	<p>0.18 Btu/hr.sqft. °F (1.02 W/m²K) 0.24 Btu/hr.sqft. °F (1.36 W/m²K)</p>

Optional features

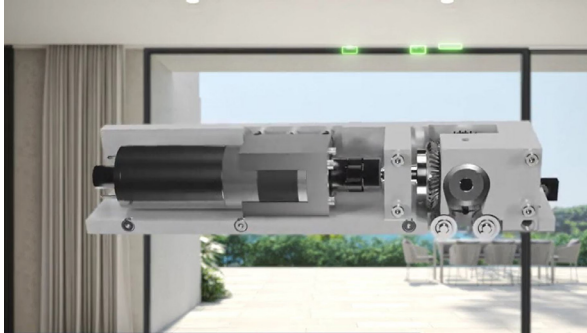

Motorization

The air-lux motor is concealed in the frames of all opening types and avoids the need for niches or recesses in the ceiling. The motorized opening and closing of the sliding window is gentle and quiet. In the event of a power failure, the sliding sash can easily be slid manually and locked without power. In the standard version, a safety cut-off is installed as a basic safety feature.

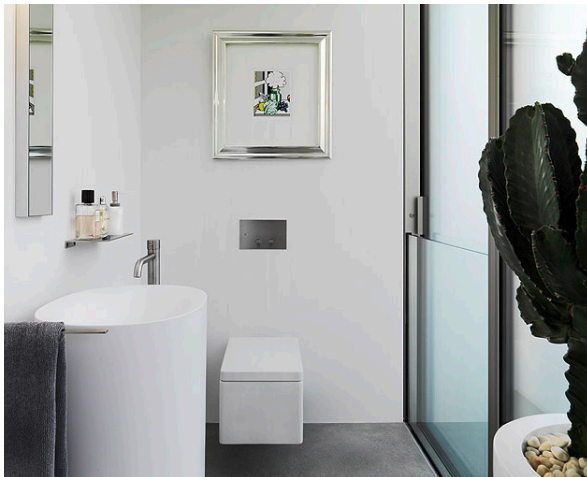

Fall protection

For constructions with no escape option, air-lux offers passive protection in the form of integrated fall protection. The laminated safety glass is installed on three sides in the frame opening.

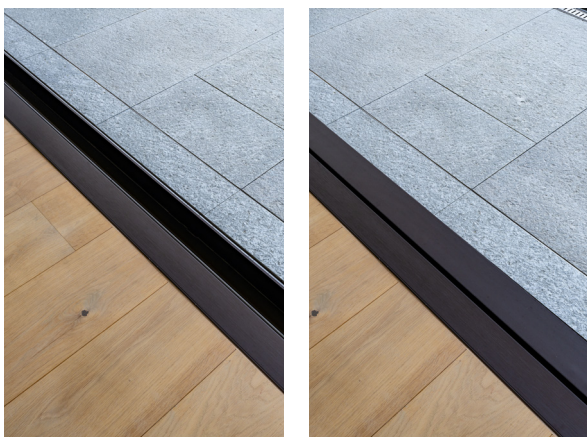

Motorized threshold

In flush sliding systems, there is a recess in the track area when the window is open. On request, air-lux can provide a motorized threshold, which ensures barrier-free access when the sliding window is open.

Optional features



Bar slider

As an alternative to the motorized threshold cover, a manual sliding threshold cover can be used in permissible instances. Due to its design, a fixed area is required to accommodate the sliding threshold cover when the element is closed. The motorized option may be used in all other cases.

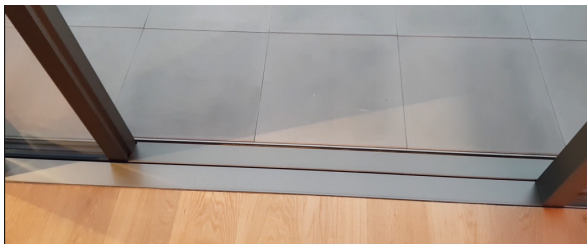

Gap ventilation

A gap ventilation feature allows the sliding element to open up to 90 mm, providing ventilation into the building. Once at 90 mm, a second press of the button locks the sliding element in place to prevent unwanted movement.

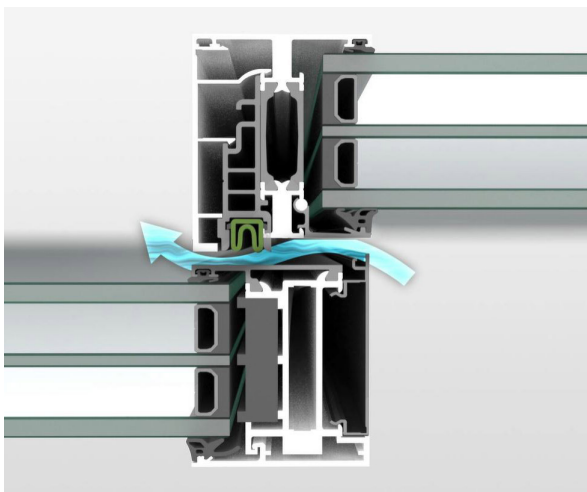

Indirect ventilation

Indirect ventilation while the sliding element is closed can be activated via a separate button or through the building management system. In this mode, the door remains securely locked while the gasket deflates, creating a 5 mm opening around the perimeter of the door. This allows for indirect ventilation and offers improved sound insulation compared to traditional window vents.

Optional features



Alarm bundle

If necessary, air-lux provides independent contacts for alarm systems that have been tested by the VdS (Verband der Sachversicherer). The air-lux alarm bundle includes a magnetic contact for position monitoring and a bolt contact for closure monitoring. All components are concealed in the system.



Building management system

Do you want to be able to monitor, open and close your air-lux sliding windows from anywhere? Directly connecting the air-lux motherboard to your building management system makes this easy.



Insect screen

An integrated insect screen, suitable for both small and large sliding sashes, is available for window heights of up to 3300 mm and opening widths of up to 850 mm. The pleated blind is operated via a discreet grip rail, allowing it to slide to the side and remain in any desired position. Thanks to its sophisticated design, it can be operated effortlessly and is fully integrated into the profile, making it invisible when the sliding window is closed.



Optional features



All-glass design

The air-lux sliding sash is also available in an all-glass design. The glass is designed with a step on two or, if desired, on all four sides. This makes the glass surface appear even larger and makes the window truly eye-catching.



All-glass design

Mullion-free corners and bi-parting sliding elements air-lux enables the realization of maximum openings with postless corner solutions or bi-parting sliding elements. Thanks to the labyrinth construction, double-stop gasket, and the optional motorized locking system with at least three locking points, these variants also ensure complete air and water tightness.



Maritime applications

In coastal regions, near swimming pools, or in industrial environments, the aggressive atmosphere places increased demands on buildings and their components. For these conditions, air-lux offers specially designed components that ensure long-term durability and system performance, even under harsh environmental influences.

Optional features



Curved/tilted

With air-lux, the only limit to design is your imagination. There are many architectural options available, not only in terms of size, but also in terms of shape and installation type.

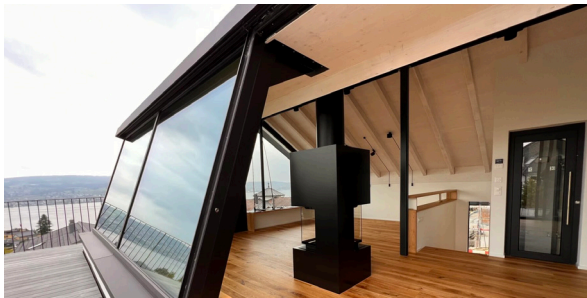

Materials

air-lux Connect Awarded by AIT architectural magazine in 2013 as a system that «achieves high aesthetic quality without compromising technical performance», air-lux Connect offers a refined selection of material finishes without sacrificing functionality. In addition to the standard aluminum version, options in bronze and a variety of premium woods are available – all with the same outstanding sealing and operational performance.

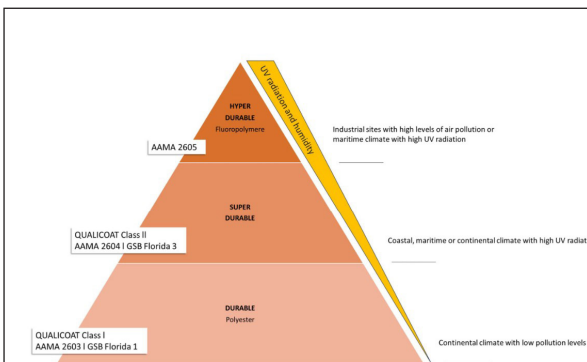

Surface

At air-lux, there are no standard colors – every element is finished according to individual customer specifications. Upon receipt of the material, components are powder-coated in the desired color or anodized for a natural metallic appearance. Both powder coating and anodizing are available, with three durability classes of powder coating offered depending on the installation location and environmental exposure.



Overview of glazing thicknesses for sash profiles

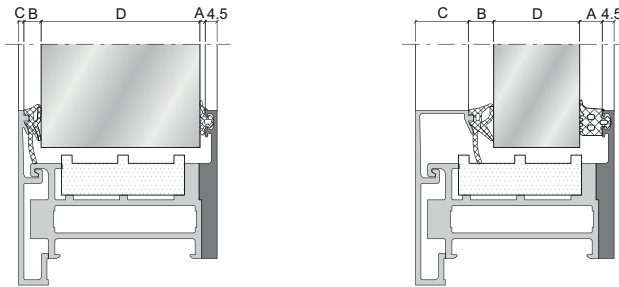

D = glazing thickness

Interior seal A	Exterior seal B						Glazing bead C
	284834	284835	284835	284836	284836	284837	
245743 (2 mm)		60	59	58	57		555160
		56		55	54	53	555320
		52	51	50	49	48	555330
		47	46	45	44	43	555340
		42	41	40	39		555350
224063 (4 mm)				38			555350
224267 (5 mm)				37			555350
284321 (6 mm)				36			555350
224268 (7 mm)				35			555350
224105 (8 mm)				34			555350
224269 (9 mm)				33			555350
224205 (10 mm)				32			555350
224313 (11 mm)				31			555350
244041 (12 mm)				30			555350
				29			555350
224312 (13 mm)					28		555350
						27	555350

Avoid these glazing thicknesses where possible. In the event of deviating tolerances, the glazing bead must be replaced.

The glazing table is based on the nominal dimensions of the profiles and filling elements. Due to different tolerances (profiles, glazing beads, glass seals and glass elements), we recommend testing your chosen outer glazing seals beforehand on an element. If necessary, the next smaller or larger glazing bead/seal can be used.

Note:

For sliding windows as in schema C with stepped-edge glazing, the minimum glazing thickness is 48 mm.

Overview of glazing thicknesses for fixed glazing

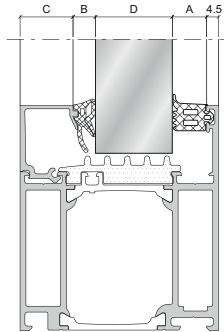
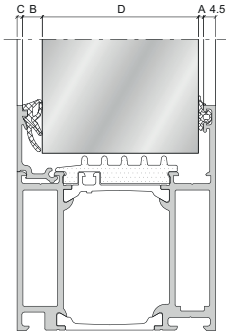

D = glazing thickness

Interior seal A	Exterior seal B						Glazing bead C
	284834	284835	284835	284836	284836	284837	
245743 (2 mm)		60	59	58	57		555150
		56		55	54	53	555280
		52	51	50	49	48	555290
		47	46	45	44	43	555300
		42	41	40	39		555310
224063 (4 mm)				38			555310
224267 (5 mm)				37			555350
284321 (6 mm)				36			555350
224268 (7 mm)				35			555350
224105 (8 mm)				34			555350
224269 (9 mm)				33			555350
224205 (10 mm)				32			555350
224313 (11 mm)				31			555350
244041 (12 mm)				30			555350
				29			555350
224312 (13 mm)					28		555350
						27	555350

Avoid these glazing thicknesses where possible. In the event of deviating tolerances, the glazing bead must be replaced.

The glazing table is based on the nominal dimensions of the profiles and filling elements. Due to different tolerances (profiles, glazing beads, glass seals and glass elements), we recommend testing your chosen outer glazing seals beforehand on an element. If necessary, the next smaller or larger glazing bead/seal can be used.

Electrical connection

- Each air-lux sliding window is fitted with a junction box, which is marked with an electrical connection sticker.



Electrical connection sticker



- All cables are clamped or soldered in this junction box.
- The junction box is located in the upper frame profile.
- All cables are labelled.
- Only one power supply is required for commissioning.

Bi-parting and postless corner sliding elements are designed for master-slave operation: The master sliding element (first opening window) requires a power supply and is responsible for all control and blocking signals. The slave sliding element (second opening window) requires a power supply.

Supply line

100–130 V AC, 50–60 Hz

200–240 V AC, 50–60 Hz

The following requirements must be observed for the supply line:

- Each window must be equipped with a voltage between 100 V AC and 130 V AC/ 200 V AC and 240 V AC.
- The connecting cables are labelled with the above sticker.
- For air-lux sliding windows, a separate fuse must be provided per floor (max. 10 windows).

Button lock

Pushbutton lock

A button lock is installed in every air-lux sliding window as standard.

- The button lock must be isolated on the building side to activate the lock. The window is locked electronically.
- A separate relay must be installed for each window!
- In the case of bi-parting and mullion-free corner sliding elements, the button lock is only connected to the master window (first opening).

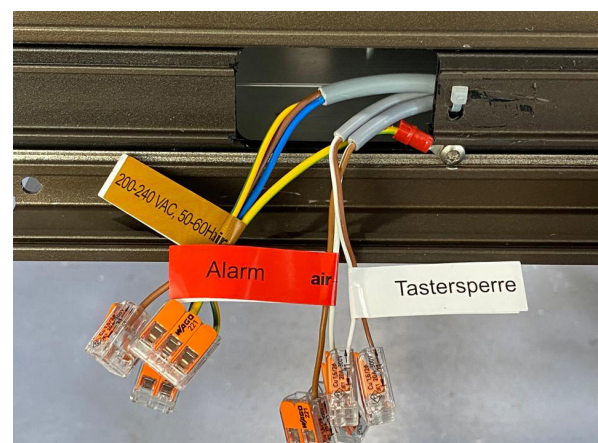

Alarm contact

Alarm

An alarm contact is fitted in every air-lux sliding sash as standard.

- The alarm contact may be supplied with max. $U = 30 \text{ V DC} / I = 2 \text{ A}$.
- When the contact is closed, the window is closed and locked.
- Since the locking bolts are evaluated electronically, a UPS (uninterruptible power supply) must be installed for the alarm system to function correctly.
- In the case of bi-parting and mullion-free corner sliding elements, the alarm contact is only connected to the master window (first opening).

VdS contacts

VdS lock contact

VdS contacts can be installed in the system on request.

- Separate VdS magnetic contact for monitoring the window in the 'CLOSED' position.
- Separate VdS magnetic contact for monitoring the window in the 'gap ventilation' position.
- Separate VdS lock contact for position monitoring of the locking bolt.
- An EKOM (electronic contactless transmitter) is installed in sliding windows with alarm glass.

External operation

In addition to the button installed as standard, external controls are also available (e.g. for building management systems, fingerprints etc.).

- Separate empty conduits must be laid for external controls. Shielded cables must be used (e.g. U72 2×4×0.8).
- All controls are isolated from the building management system.
- In the case of bi-parting and mullion-free corner sliding elements, a separate control is required for both sliding windows.

Electrical connections at the top

Manual version

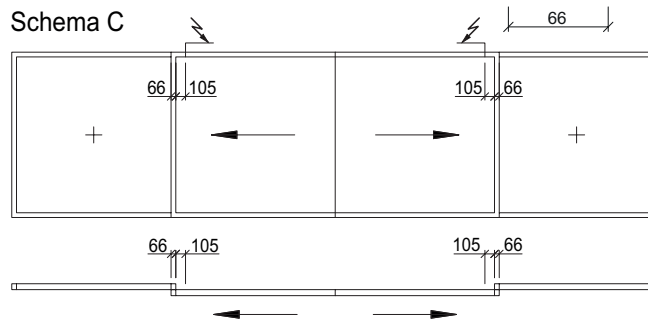
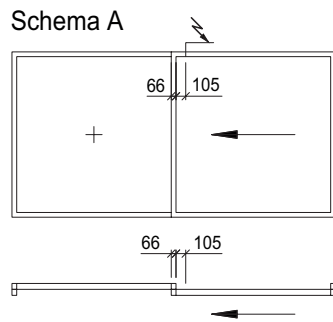
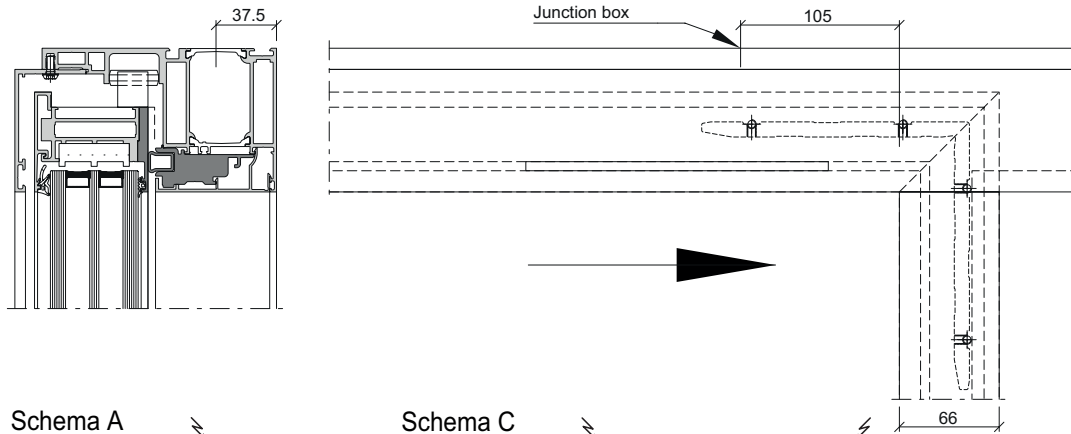

Motorized version

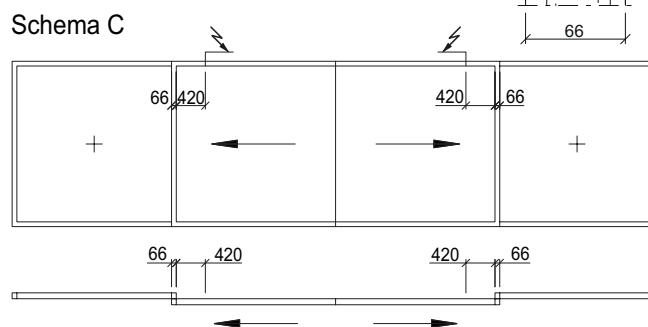
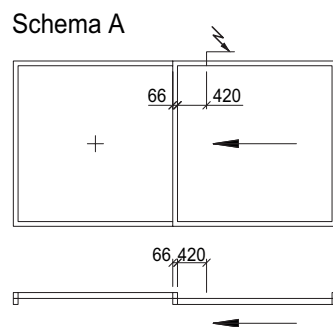
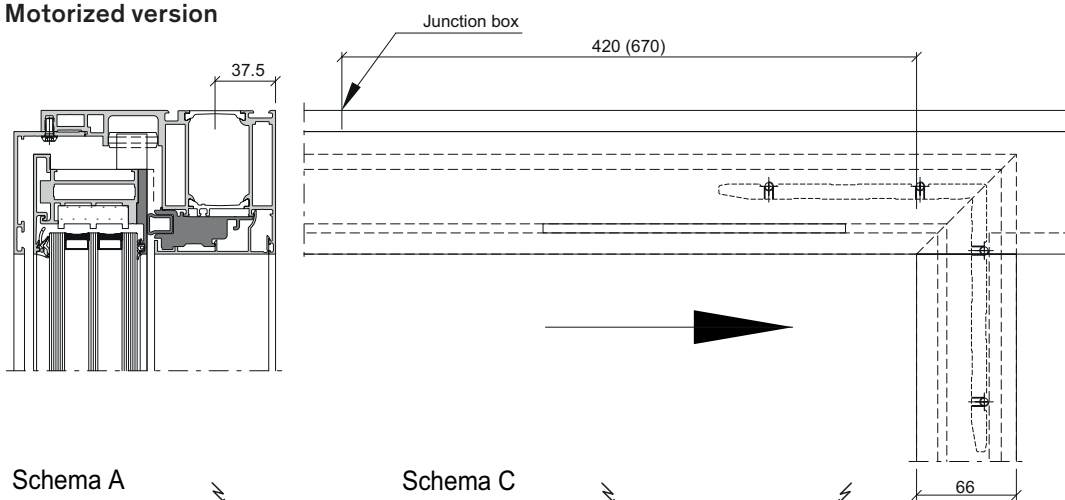

Exception: For sliding windows schema A Pocket or sliding windows that are not accessible from the outside, the junction box is 670 mm (motorized version).

Further applications with the air-lux sealing system



air-lux PD 75 pivot door

Pivot doors are a striking solution for large-scale entrance areas. Thanks to precision-engineered asymmetrical pivot hinges and button technology, the door swings open effortlessly on both sides. The PD 75 is available in exceptionally large formats and offers extensive design flexibility – fully customizable in glass, metal, and various other materials.

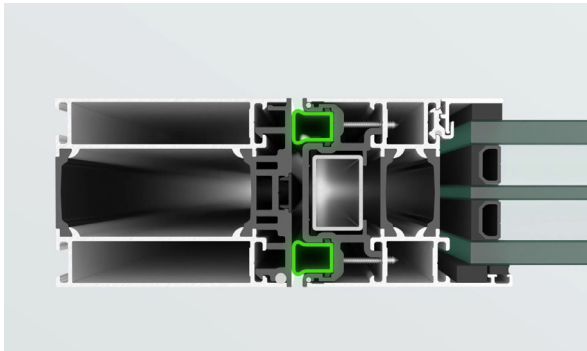

air-lux DW M-XL – Descending Window

Equipped with the same high-performance sealing technology used in all air-lux elements, the descending window descends fully into the floor at the push of a button – creating a seamless transition between interior and exterior space.

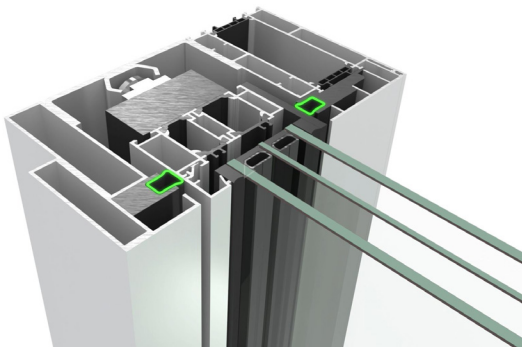



Brochures

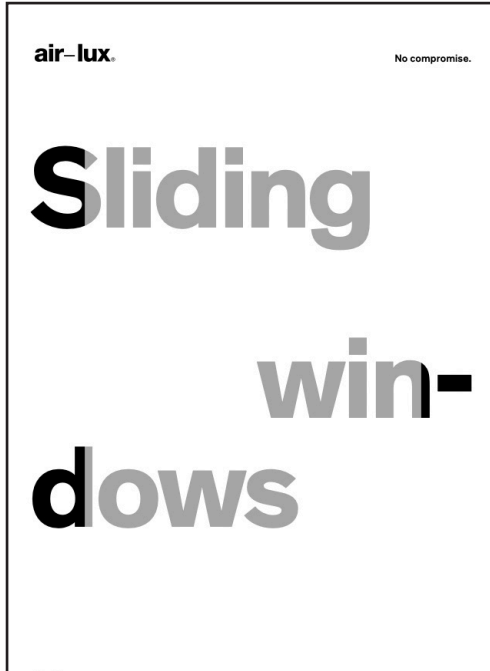

Air-Lux Technik AG

Breitschachenstrasse 52
9032 Engelburg SG
Schweiz
T +41 71 272 26 00
info@air-lux.ch
www.air-lux.ch

Ein Produkt von

KRAPF ■ |